

# 390

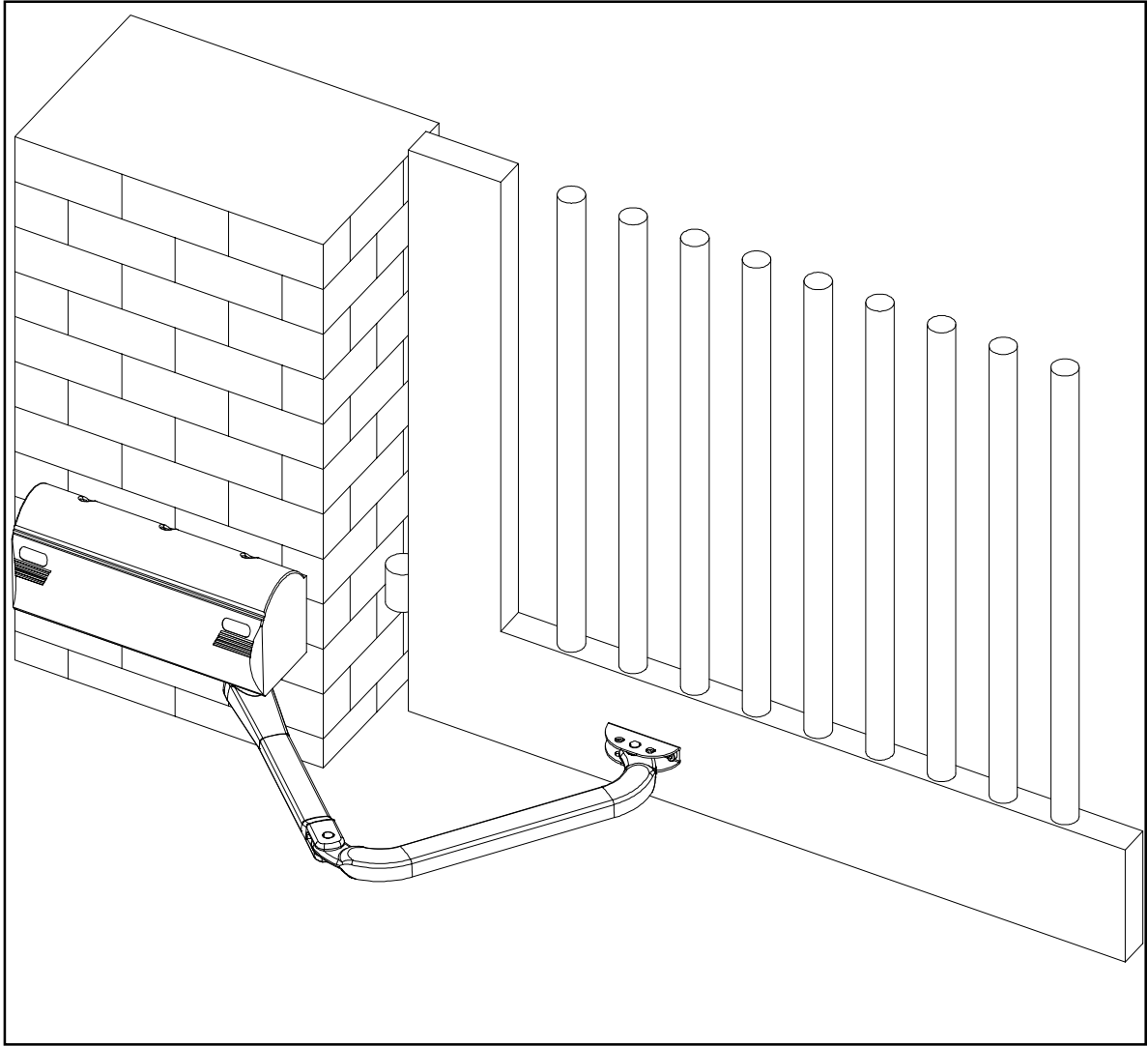

# FAAC



FAAC para la naturaleza  
100% papel reciclado



FAAC ist umweltfreundlich  
100% Altpapier



FAAC pour la nature  
papier recyclé 100%



FAAC for nature  
recycled paper 100%



FAAC per la natura  
carta riciclata 100%



# AUTOMATION FAAC 390

These instructions apply to the following model:

## FAAC 390

The external automation 390 with articulated arms automates residential swing-leaf gates with leaves of up to 3m in length, and is ideal for applications on large pilasters without the need to provide niches (sometimes required to observe the installation dimensions of piston driven devices).

It consists of an irreversible electro-mechanical operator with guard and an articulated-arm activation system to be fitted to the gate with the appropriate accessories.

The irreversible system ensures the gate is mechanical locked when the motor is not operating. No lock need be installed for leaves up to 1,8 m. in length.

A manual release makes it possible to move the gate in the event of a power-cut or fault.

**To obtain anti-crushing protection, you have to use electronic appliances with a torque control electronic device. The automation 390 was designed and manufactured to control access of vehicles. Avoid any other use whatever.**

## 1. DESCRIPTION AND TECHNICAL SPECIFICATIONS

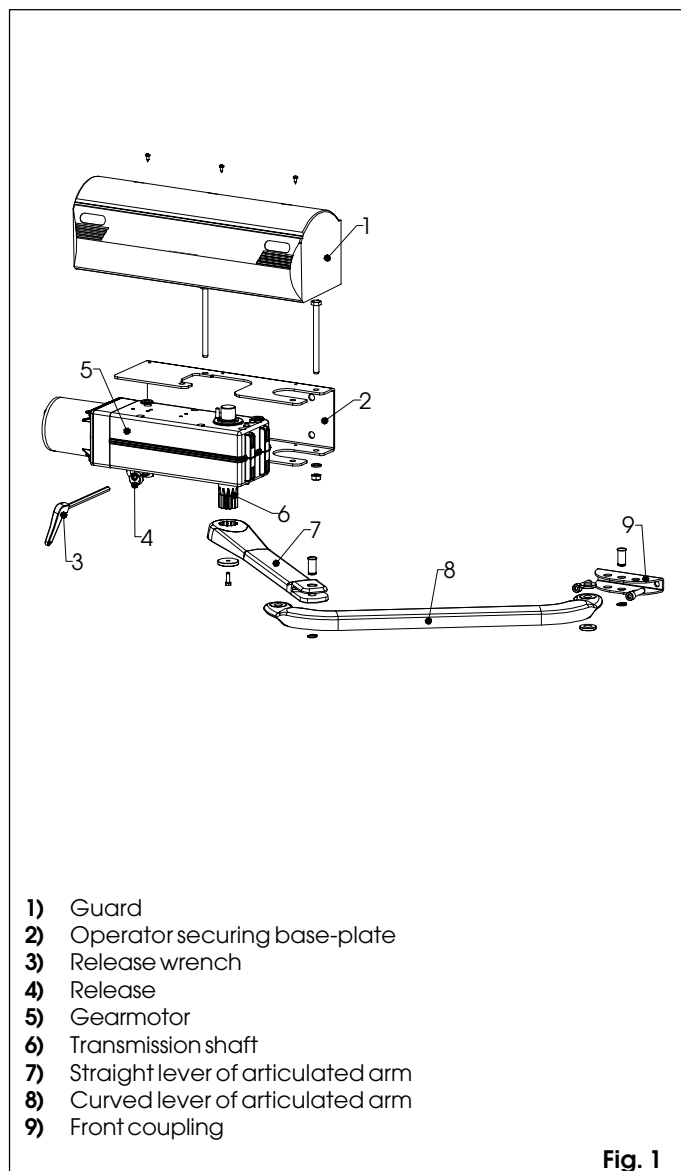

**TAB. 1 TECHNICAL SPECIFICATION OF OPERATOR**

MODEL	FAAC390
Power supply	230V (+6% -10%) 50Hz (60Hz)
Power absorption	280W
Current absorption	1.2A
Max torque	250Nm
Starting capacitor	8µF
Thermal protection for winding	140°C
Reduction ratio	1:700
Angular velocity	8°/sec
Ambient temperature	-20°C +55°C
Use frequency (cycles / hour)	15
RPM	960
Weight of gearmotor	11.5 kg
Protection class	IP44
Gearmotor overall dimension	see fig.2
Leaf max length	1,8 m (without electric lock) 3 m (with electric lock)

## 2. DIMENSIONS

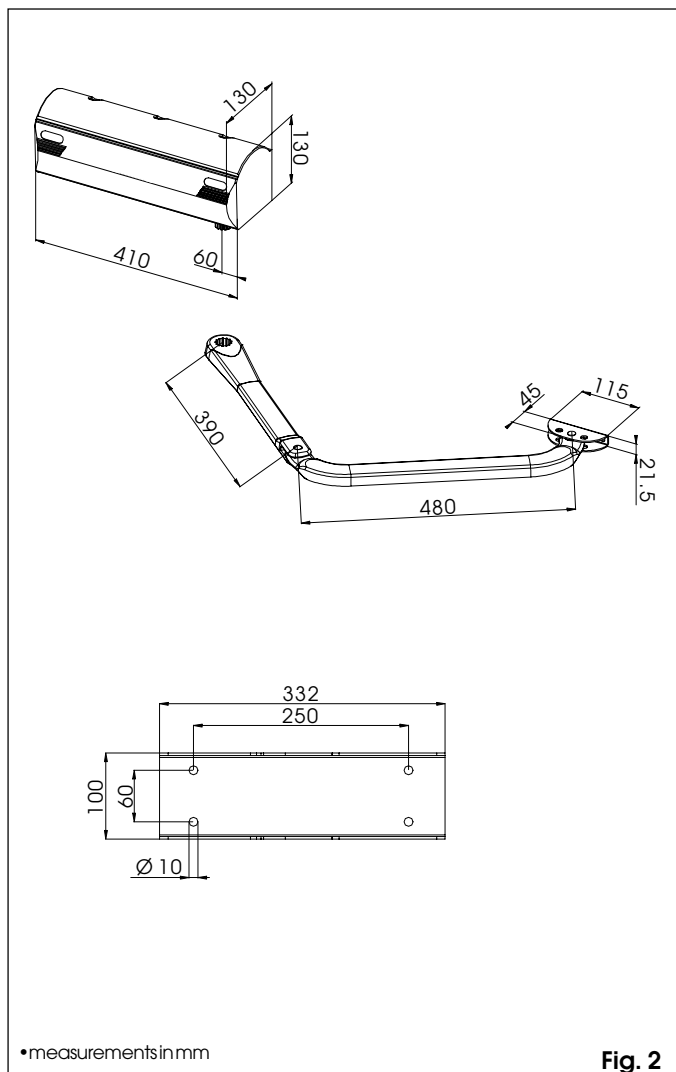

3. ELECTRICAL EQUIPMENT (standards system)

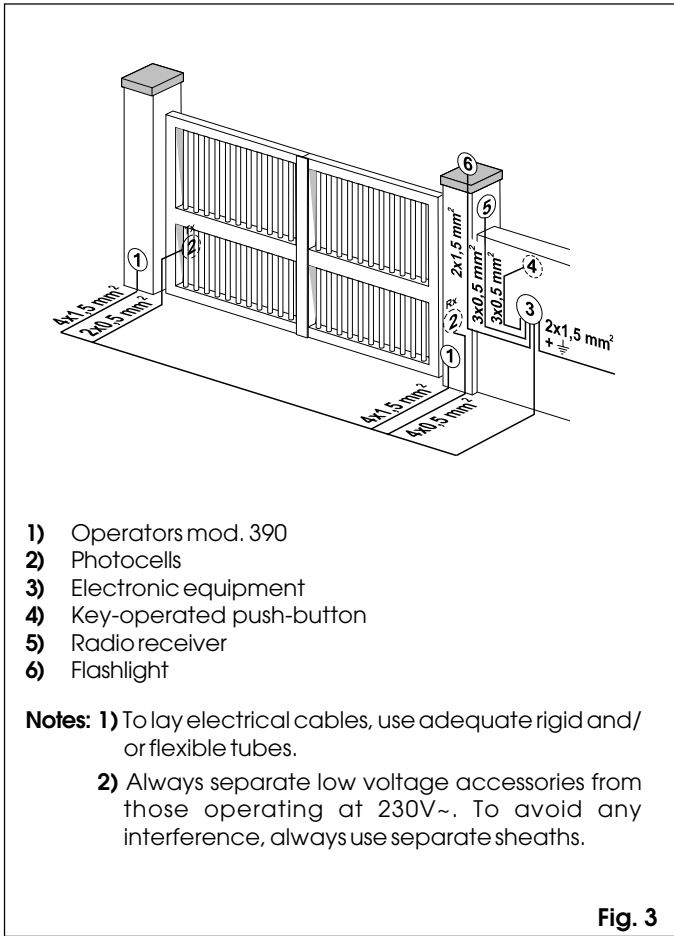

4. INSTALLATION OF AUTOMATION

4.1. PRELIMINARY CHECKS

To ensure safety and an efficient automation, make sure the following requirements are met:

- The gate structure must be suitable for automation. In particular, make sure it is sufficiently sturdy and rigid, and that its dimensions are in line with those indicated in the technical specifications.
- Make sure that the leaves move properly and uniformly, without any irregular friction during their entire travel.
- Check if hinges are in good condition.
- Make sure the travel limit mechanical stops are present.
- We advise you to carry out any metalwork jobs before installing the automation.

4.2. INSTALLATION DIMENSIONS

Establish the installation position of the operator by consulting Fig. 4-5-6.

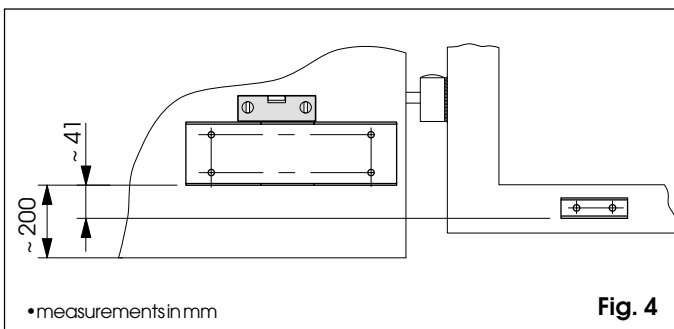

4.2.1. RECOMMENDED DIMENSIONS FOR INWARD OPENING

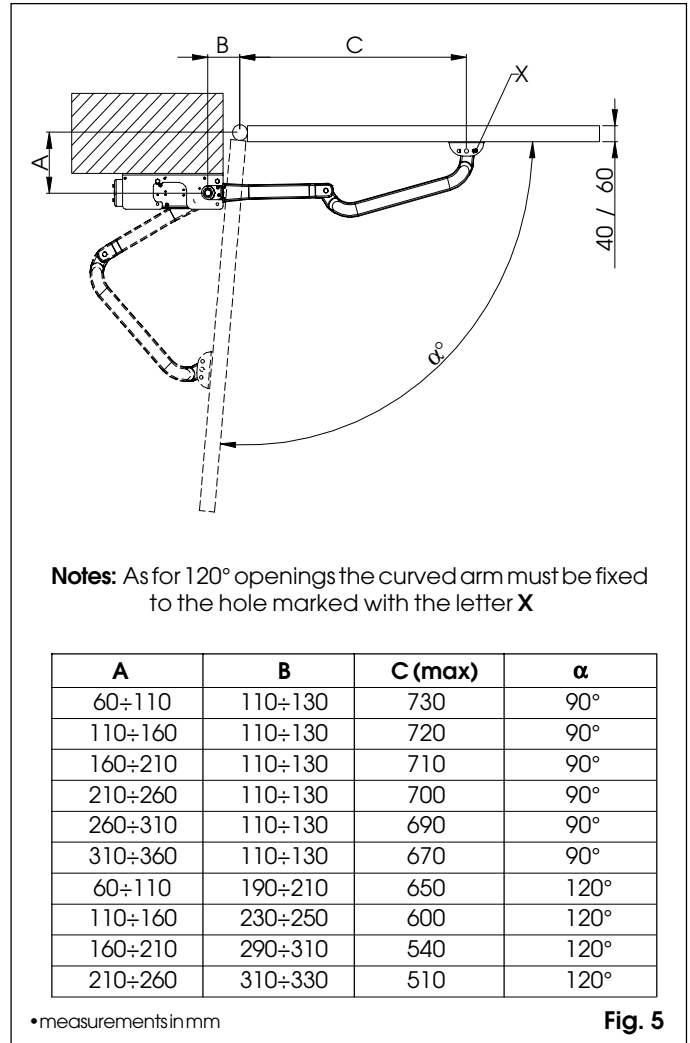

4.2.2. RECOMMENDED DIMENSIONS FOR OUTWARD OPENING

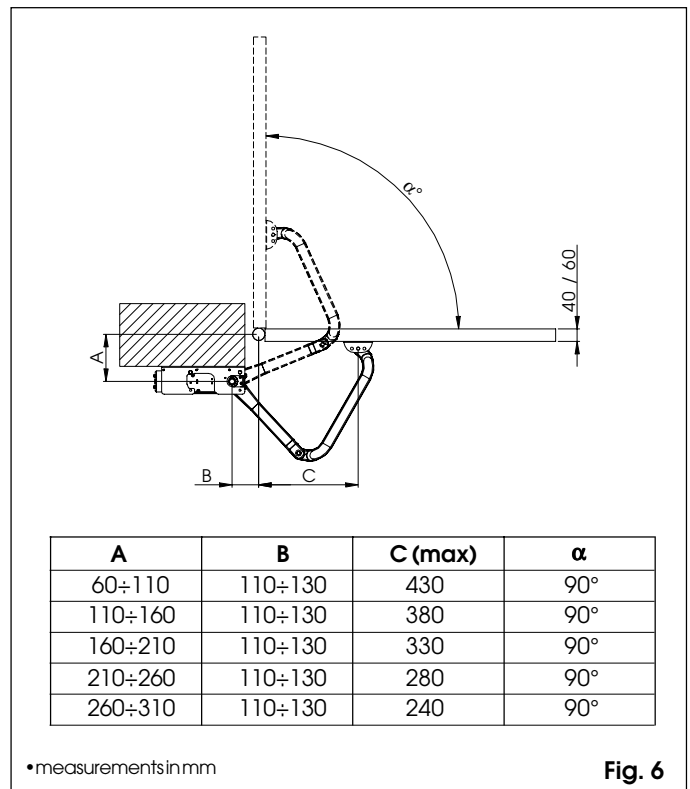

**4.3. INSTALLATION STEPS**

The operator 390, base-plate and articulated arm are designed either for right-hand or left-hand (Fig. 7) installation.

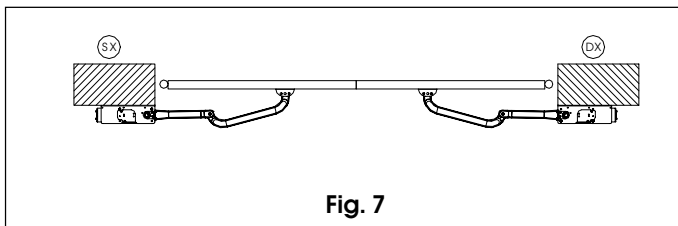

Fig. 7

- Secure the base-plate to the pilaster, using Ø10 screws and suitable expansion plugs (Fig. 8), and check it is perfectly horizontal.
- Fit the gearmotor unit on the base-plate and secure it with the two screws, nuts and flexible washers (Fig.8).
- The transmission shaft must always face downward.

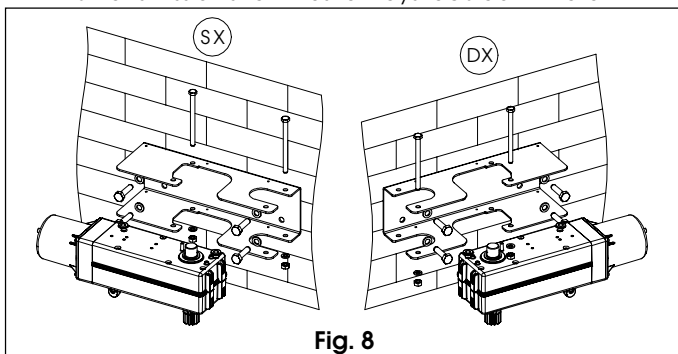

Fig. 8

- Assemble the articulated arm and front coupling as shown in Fig. 9.

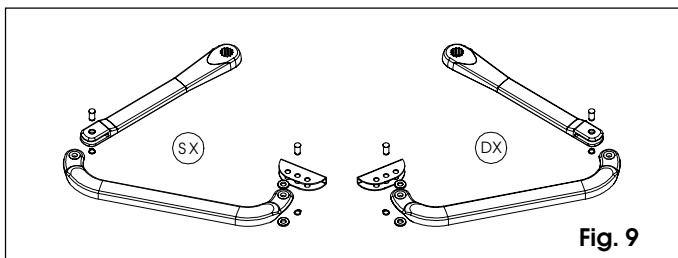

Fig. 9

- Fit the straight lever of the articulated arm on the gearmotor shaft and tighten it with the supplied screw and washer (Fig. 10).
- Release the operator (chapter 5.)
- Establish the securing position of the front coupling on the leaf, observing dimension "C" defined previously (chapter 4.2). Check that arm and coupling are perfectly horizontal.
- The coupling may be welded directly onto the leaf (Fig. 11) or screwed by using the threaded inserts (Fig. 12).

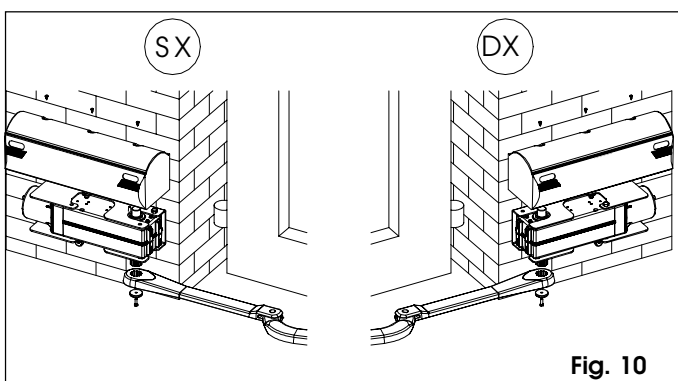

Fig. 10

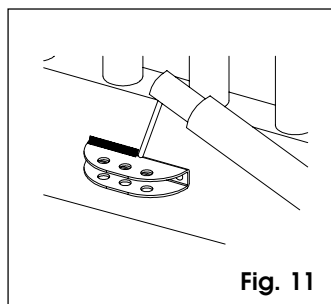

Fig. 11

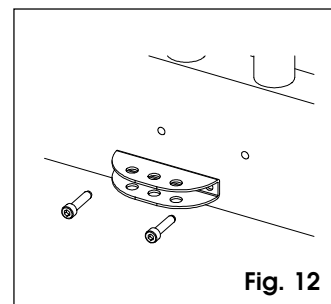

Fig. 12

- In both cases, provisionally remove the coupling from the arm in order to secure it.
- Fit the guards on the operator (Fig. 10).
- Re-lock the operator (chapter 6.)
- Make the electrical connections of the selected electronic appliance, observing the annexed instructions.

**4.4. TEST OF THE AUTOMATION**

When you have finished installation, carefully check the operating efficiency of the automation and of all accessories connected to it, safety devices in particular.

Hand the "User's Guide" page to the Client, and describe how the operator should function and be used correctly, stressing the potentially dangerous areas of the automation.

**5. MANUAL OPERATING MODE**

If the gate has to be operated manually in the event of a power-cut or fault to the automation, use the release device as follows:

- Fit the supplied Allen wrench and turn it by about a half turn until it stops, in the direction shown in Fig. 13, depending on type of installation.

**6. RESTORING NORMAL OPERATING MODE**

To avoid an involuntary pulse from activating the gate during the manoeuvre, before re-locking the operator, switch off power to the system.

- Fit the supplied Allen wrench and turn it by about a half turn until it stops, in the direction shown in Fig. 13, depending on type of installation.

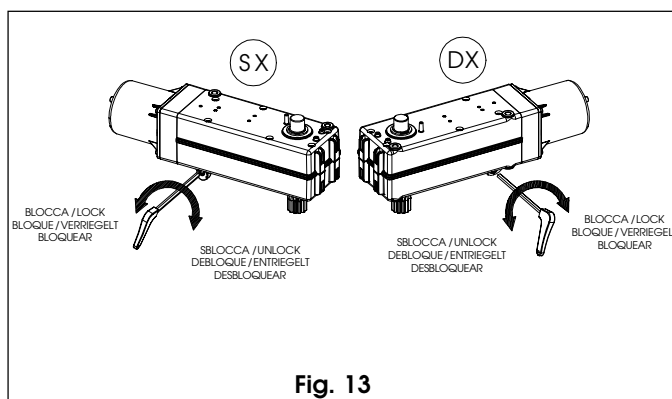

Fig. 13

**7. MAINTENANCE**

Do the following jobs at least every six months:

- Check if motor torque is correctly set.
- Check efficiency of the release system.
- Check efficiency of safety devices.

**8. REPAIRS**

For any repairs, contact our authorised Repair Centres.

## End-user guide

# AUTOMATION FAAC 390

Read the instructions carefully before using the product, and keep them for future consultation.

### GENERAL SAFETY REGULATIONS

If installed and used correctly, the automation 390 will ensure a high degree of safety.

Some simple rules regarding behaviour will avoid any accidental trouble:

- Do not pass through the leaves while they are moving. Before passing through the leaves, wait until they are fully open.
- Do not, on any account, stand between the leaves.
- Do not stand near the automation and do not allow children and other people to stand there, especially while it is operating.
- Keep remote controls or any other pulse generator well away from children to prevent the automation from being activated involuntarily.
- Do not allow children to play with the automation.
- Do not willingly obstruct movement of the leaves.
- Do not allow branches or shrubs to interfere with leaf movement.
- Keep illuminated signalling systems efficient and clearly visible.
- Do not attempt to activate the leaves manually unless you have released them first of all.
- In the event of a malfunction, release the leaves to allow access and wait for qualified personnel to take appropriate action.
- After enabling manual operating mode, switch off the power supply to the system before restoring normal operating mode.
- Do not make any alterations to the components of the automation.
- Do not attempt to repair or adjust the system personally, but contact qualified personnel only.
- Call in qualified personnel at least every 6 months to check the efficiency of the automation, safety devices and earth connection.

### DESCRIPTION

These instructions apply to the following model:

#### FAAC 390

FAAC 390 automation for residential swing-leaf gates consists of an irreversible electro-mechanical operator with guard and an articulated-arm activation system fitted to the gate with the appropriate accessories.

The irreversible system ensures the gate is mechanically locked when the motor is not operating. No lock need be installed for leaves up to 1,8m in length.

A manual release makes it possible to move the gate in the event of a power-cut or fault.

The operators are supervised by an electronic control unit, housed in a container adequately protected against atmospheric agents.

The leaves are normally in closed position.

When the electronic control unit receives an opening command by remote control or by any other pulse generator, it activates the operator to rotate the leaves until they are sufficiently open to provide access.

If automatic operating mode was set, the leaves close on their own after the selected pause time has elapsed.

If semi-automatic operating mode was set, a second pulse must be sent to allow the leaves to close again.

A stop pulse (if supplied) always stops movement.

For detail on operation of the automation under different operational logics, consult the installation technician.

The automations include safety devices (photocells, sensitive edges, ...) which prevent the leaves from moving when there is an obstacle in the area they protect.

The automation 390 requires use of electronic appliances with an electronic torque control device.

The light indicates that leaves are moving.

### MANUAL OPERATING MODE

If the gate has to be operated manually in the event of a power-cut or automation fault, use the release device as follows:

- Fit the supplied Allen wrench and turn it by about a half turn until it stops, in the direction shown in Fig. 1-2, depending on type of installation.

### RESTORING NORMAL OPERATING MODE

To avoid an involuntary pulse from activating the gate during the manoeuvre, before re-locking the operator, switch off power to the system.

- Fit the supplied Allen wrench in the release device and turn it by about a half turn until it stops, in the direction shown in Fig. 1-2, depending on type of installation.
- The release device can be activated without removing the guard.

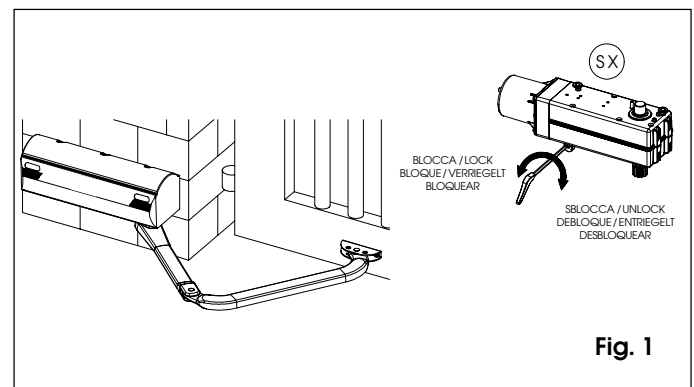

Fig. 1

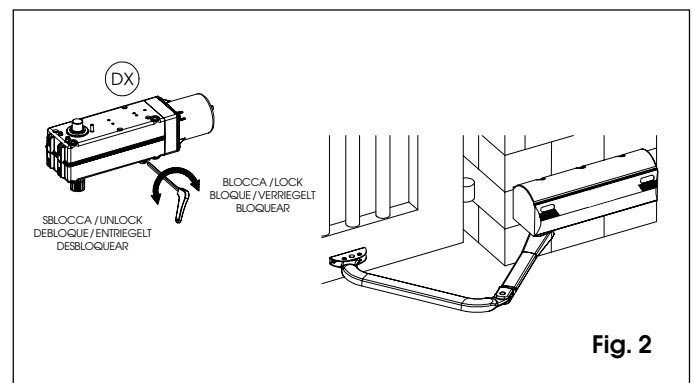

Fig. 2